

# SIREN SPEAKERS / SPARES

## UST: Unique Siren Tube



With the continued development of new cars and compact engine size, available space under the bonnet is more limited than ever before. The UST has been specifically designed with this in mind utilising minimal space availability.



### MODEL NUMBERS:

#### Full Unique Siren Tube Kits:

- UST: Full UST kit
- UST-ECON: Full UST kit (Economy Version)
- UST-MINI: Full MINI UST Kit
- UST-MINIEC: Full MINI UST Kit (Economy)

Full UST kits come with the Whelen® SD210 speaker driver, Whelen® rubber tubing and and Woodway aluminium flare tube. Economy kits come with both the same driver and the speaker flare, however the tubing is not reinforced or manufactured directly by Whelen®.

#### Partial Unique Siren Tube Kits:

- UST-KIT: Partial Kit (no speaker driver)
- UST-KIT2: Partial Kit (no rubber tubing)



Standard UST



MINI UST

### DIMENSIONS:

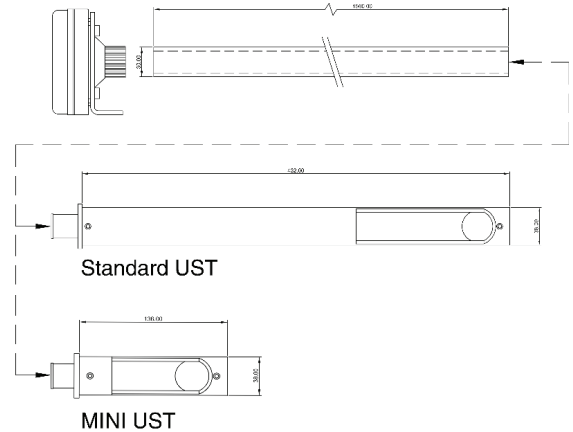

## Project A-Flex®

Project-A-Flex. Speaker horn and driver may be installed separately under the bonnet of even the most compact of vehicles. 1.5m acoustical tube connects the speaker horn to the driver. Complete with 100W driver and mounting kit. Also available as a kit for use with customer supplied drivers. Weight 4.5kg



### MODEL NUMBERS:

- PROJECT: Kit with driver
- PROJECTK: Kit with customer supplied drivers



### DIMENSIONS:

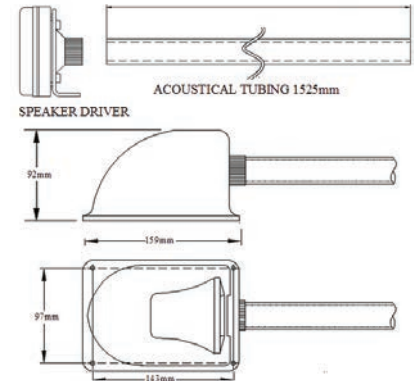

## SA315P

Smaller size speaker with full-size performance will mount in more locations than ever before. The SA315P installs easily and delivers traffic clearing warning where it is needed. Weight 3kg



### MODEL NUMBER:

- SA315P-UK: Siren Speaker (includes mounting bracket)

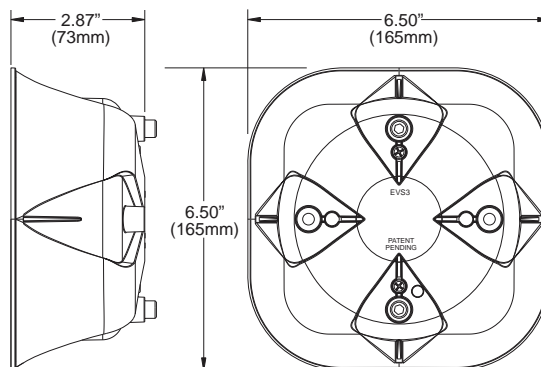

Short, round aluminium speaker flare adaptable for most covert installations and motorcycle applications. Weight 3.5kg



**MODEL NUMBERS:**

**SA340STS:** Siren Speaker

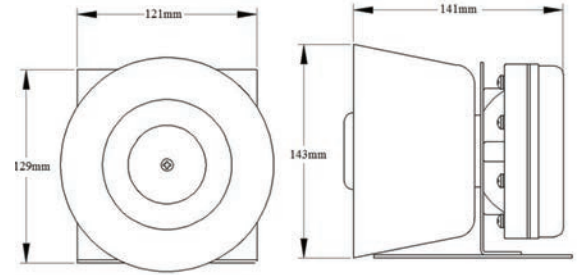
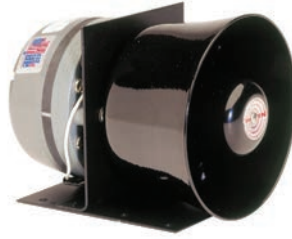

## SA40

SA40 Lightbar mounted speaker, for use on the Freedom LED Series lightbars. Weight 5.5kg



**MODEL NUMBERS:**

**SA40:** Siren Speaker

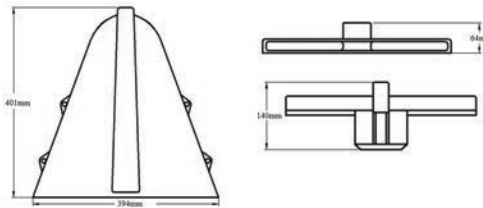

## SD210

Replacement Speaker Driver for use with Whelen® siren systems.



**MODEL NUMBERS:**

**SD210RX:** Speaker driver without thread. Applications: SA315P Speaker

**SD210R:** Speaker driver with thread. Applications: UST (Unique Siren Tube), Project A Flex and SA340STS Speakers.



## Siren Testing Volume Reduction Unit

Designed for use in confined situations e.g. workshops when testing sirens. When fitted to a Woodway siren system the unit reduces the volume of the siren.

**MODEL NUMBER:**

**STVRUI2:** Siren Testing Volume Reduction Unit (12V/24V)

