

WHELEN[®]

ENGINEERING COMPANY INC.

51 Winthrop Road
Chester, Connecticut 06412-0684
Phone: (860) 526-9504
Fax: (860) 526-4078
Internet: www.whelen.com
Sales e-mail: autosale@whelen.com
Canadian Sales e-mail: autocan@whelen.com
Customer Service e-mail: custserv@whelen.com

Installation Guide: 8-Outlet Relay Box Model PCC8R

Safety First

This document provides all the necessary information to allow your Whelen product to be properly and safely installed. Before beginning the installation and/or operation of your new product, the installation technician and operator must read this manual completely. Important information is contained herein that could prevent serious injury or damage.

- **Proper installation of this product requires the installer to have a good understanding of automotive electronics, systems and procedures.**
- **If mounting this product requires drilling holes, the installer MUST be sure that no vehicle components or other vital parts could be damaged by the drilling process. Check both sides of the mounting surface before drilling begins. Also de-burr the holes and remove any metal shards or remnants. Install grommets into all wire passage holes.**
- **If this manual states that this product may be mounted with suction cups, magnets, tape or Velcro®, clean the mounting surface with a 50/50 mix of isopropyl alcohol and water and dry thoroughly.**
- **Do not install this product or route any wires in the deployment area of your air bag. Equipment mounted or located in the air bag deployment area will damage or reduce the effectiveness of the air bag, or become a projectile that could cause serious personal injury or death. Refer to your vehicle owner's manual for the air bag deployment area. The User/Installer assumes full responsibility to determine proper mounting location, based on providing ultimate safety to all passengers inside the vehicle.**
- **For this product to operate at optimum efficiency, a good electrical connection to chassis ground must be made. The recommended procedure requires the product ground wire to be connected directly to the NEGATIVE (-) battery post.**
- **If this product uses a remote device to activate or control this product, make sure that this control is located in an area that allows both the vehicle and the control to be operated safely in any driving condition.**
- **Do not attempt to activate or control this device in a hazardous driving situation.**
- **If this product contains strobe light(s), halogen light(s) or high-intensity LEDs, do not stare directly into these lights at a close distance. Momentary blindness and/or eye damage could result.**
- **If this product contains strobe light(s), halogen light(s) or high-intensity LEDs, use only soap and water to clean the lamp lens. Use of other chemicals could result in premature lens cracking (crazing) and discoloration. Lenses in this condition have significantly reduced effectiveness and should be replaced immediately. Inspect and operate this product regularly to confirm its proper operation and mounting condition. Do not use a pressure washer to clean this product.**
- **It is recommended that these instructions be stored in a safe place and referred to when performing maintenance and/or reinstallation of this product.**
- **FAILURE TO FOLLOW THESE SAFETY PRECAUTIONS AND INSTRUCTIONS COULD RESULT IN DAMAGE TO THE PRODUCT OR VEHICLE AND/OR SERIOUS INJURY TO YOU AND YOUR PASSENGERS!**

For warranty information regarding this product, visit www.whelen.com/warranty

Selecting a mounting location...

The logical choice for a mounting area would be a trunk or similar compartment. However, due to the wide variety of vehicles onto which the relay box could be installed, this is not always possible. The following guidelines will help the installer select an acceptable alternative:

- **Do not select a location where the relay box will be exposed to potential damage from any unsecured or loose equipment in the vehicle.**
- **Be sure the area selected will not allow the relay box to be exposed to water!**
- **When routing the relay box's wires, it is important to choose a path that will keep these wires away from excessive heat and from any vehicle equipment that could compromise the integrity of the wires (ex. trunk lids, door jams, etc.)**

When the best mounting location has been determined, securely fasten the relay box to it's mounting surface using the supplied hardware.

Caution: As it will be necessary to drill holes into the mounting surface, the installer **MUST** be sure that no vehicle components or other vital parts could be damaged by the drilling process. Check both sides of the mounting surface before drilling!

Wiring...

Relay Power - Using appropriately sized wires (see chart on Page 3), extend the two Main Power wires to the vehicle battery. Install a Fuse Block equipped with a 40 Amp fuse onto the end of each wire. Connect each fuse block to the POS (+) battery terminal. NOTE: Do not place the fuses in their holders until all electrical connections have been completed.

WARNING! Combined relay current can not exceed 70 Amps at any time!

WARNING! All customer supplied wires, that connect to the positive (+) terminal of the battery, must be sized to supply at least 125% of the maximum operating current, and fused "at the battery" to carry the load! DO NOT USE CIRCUIT BREAKERS WITH THIS PRODUCT!

System Wiring - Using appropriately sized wire, extend the wires from the 'System' port as follows:

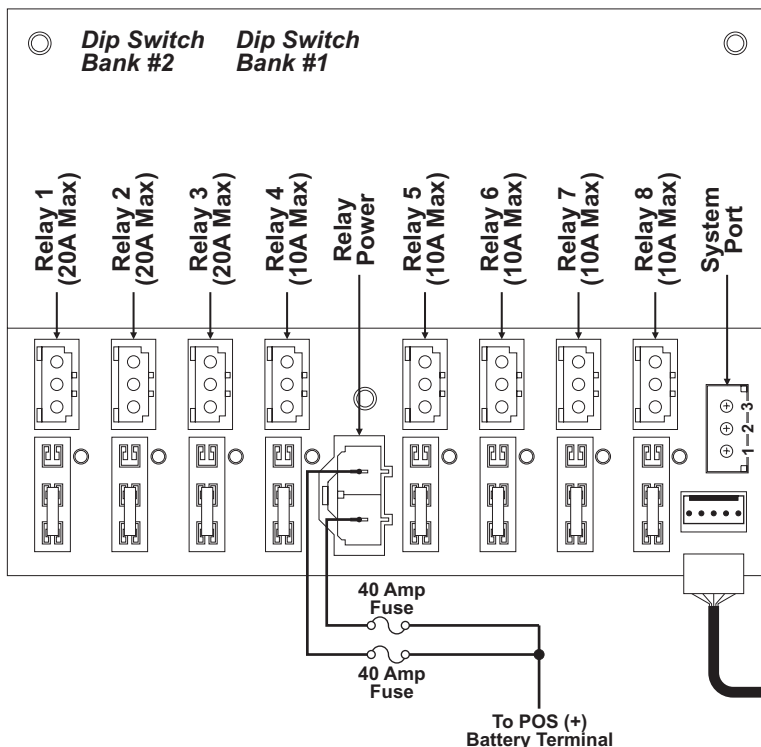

Pin 1 - to an ignition controlled electrical circuit.

Pin 2 - to Chassis Ground.

Pin 3 - to vehicle parking light circuit (backlight connection).

Relay Connections - Each relay can function as either a Dry Contact Relay or as a Standard Outlet. The function is determined by the position of that relay's fuse. Refer to the illustration below for wiring information.

Dip Switches...

The relay box has two dip switch banks that are accessible from the rear of the unit. Each bank consists of 8 dip switches; one for each relay. For example, the position of dip switch #6 will effect relay #6.

Bank #1 is used to disable diagnostic feedback for a given relay configured to operate as a Dry Contact Relay. In the UP (default) position, the outlet will return diagnostic feedback to the control head. In the DOWN position, no diagnostic information for that outlet is sent to the control head.

Bank #2 determines the operational style of the control head buttons. In the UP (default) position, the buttons operate with a "Push ON / Push OFF" style. In the DOWN position, the buttons function in a "Momentary" style, with the relay being active only while its corresponding button is pressed.

Diagnostics...

The RELAY BOX provides diagnostic feedback to the control head. **NOTE:** The diagnostic operation for that relay should be disabled as outlined in the "Dip Switch" section.

The diagnostic LED for each relay is located adjacent to the control head button for a given relay and operates as follows:

LED On Steady - Relay is operating properly

LED Single Flash - Relay has failed to close

LED Double Flash - Relay is stuck closed.

WARNING! If a diagnostic LED indicates a problem, do not operate that relay until the cause has been identified and repaired.

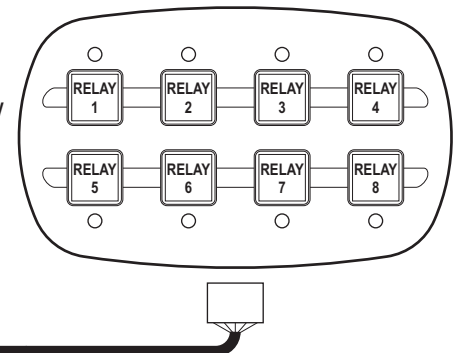
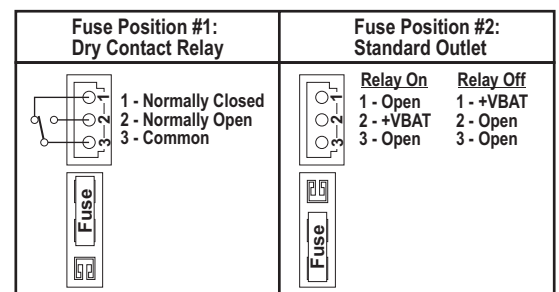

Wire Gauge Calculation Chart

		Wire Gage (AWG)										
		22	20	18	16	14	12	10	8	6	4	2
Current Draw (AMPS)	5	6	9.5	15	24.5	39	62	98	156	248	395	629
	10	3	5	7.5	12	19.5	31	49	78	124	197	314
	15	INS.	3	5	8	13	20.5	32.5	52	82.5	131	209
	20	INS.	INS.	4	6	9.5	15.5	24.5	39	62	98.5	157
	25	INS.	INS.	3	5	8	12.5	19.5	31	49.5	79	125
	30	INS.	INS.	INS.	4	6.5	10.5	16.5	26	41.5	66	104
	35	INS.	INS.	INS.	3.5	5.5	9	14	22.5	35.5	56.5	89.5
	40	INS.	INS.	INS.	3	5	7.5	12.5	19.5	31	49.5	78.5
	45	INS.	INS.	INS.	INS.	4.5	7	11	17.5	27.5	44	69.5
	50	INS.	INS.	INS.	INS.	4	6	10	15.5	25	39.5	63
	55	INS.	INS.	INS.	INS.	3.5	5.5	9	14	22.5	36	57
	60	INS.	INS.	INS.	INS.	3	5	8	13	20.5	33	52.5
	65	INS.	INS.	INS.	INS.	3	5	7.5	12	19	30.5	48.5
	70	INS.	INS.	INS.	INS.	3	4.5	7	11	17.5	28	45
	75	INS.	INS.	INS.	INS.	INS.	4	6.5	10.5	16.5	26.5	42
	80	INS.	INS.	INS.	INS.	INS.	4	6	10	15.5	24.5	39
	85	INS.	INS.	INS.	INS.	INS.	3.5	6	9	14.5	23	37
	90	INS.	INS.	INS.	INS.	INS.	3.5	5.5	8.5	14	22	35
	95	INS.	INS.	INS.	INS.	INS.	3.5	5	8	13	21	33
	100	INS.	INS.	INS.	INS.	INS.	3	5	8	12.5	19.5	31.5

INS. = Insufficient All Distances Shown Are In Feet

To use this chart...

1. Determine the amount of current being drawn through the wire. Locate this number in the vertical left-hand column. If the current value is between adjacent values, use the higher number.

2. Follow this row until the length of the installed wire is shown. If the exact length is between adjacent values, use the higher number. Follow this column upwards to find the recommended size (gage) for this wire.

In the example shown below, the size for a wire with an installed length of 36 feet, through which 22 amps of current will be drawn, must be determined.

A row for 22 amps is not shown, so the row for 25 amps will be used. Follow this row to the right. A column for 36 feet is not show, so the column for 49.5 feet will be used. Following this column to the top will show that the size of this wire must be at least 6 gage.